

RoHS Compliance

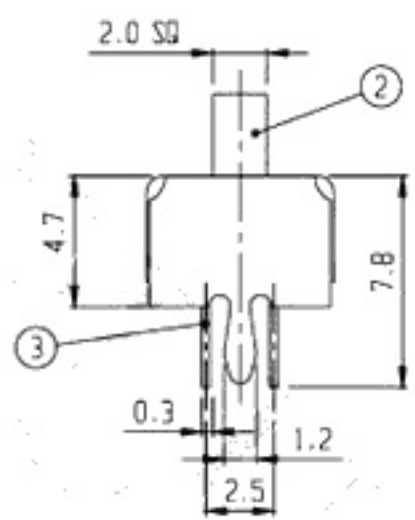
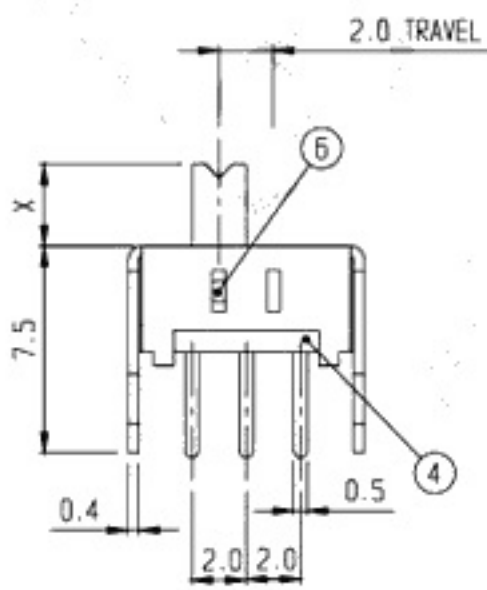
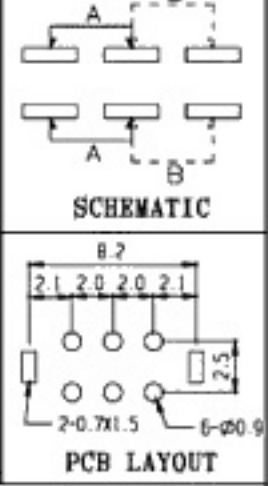

5	CONTACT	P B S	2	Ag PLATED	6	SPRING	P B S	1	
3	TERMINAL	BRASS	6	Ag PLATED	4	TERMINAL BASE	PHENOL RESIN	1	NATURAL
1	FRAME	S P C C	1	Ni PLATED	2	KNOB	P O M	1	VG 2-7
NO	PART	MATERIAL	QTY	REMARKS	NO	PART	MATERIAL	QTY	REMARKS

ISSUED SPECIFICATION TITLE: SLIDE SWITCH (2P2T)

RATING: DC 30V 0.3A
 CONTACT RESISTANCE: 30mΩ max.
 INSULATION RESISTANCE: 500MΩ at 500V DC
 WITHSTAND VOLTAGE: AC 500V for 1 minute
 OPERATION FORCE: REFER ATTACH SPECIFICATION
 SWITCHING LIFE: 10K cycles min.

MODEL NO: SS-22D03 (VG)

TOLERANCE	UNIT: MM	DWN.	hoo
UP TO 1.0:±0.1	SCALE: 4:1	CHK'D.	hm
1.0 TO 10.0:±0.2	VERSION: 01	APPD.	
OVER 10.0:±0.3	DRWG NO:		

