

REV	MODIFICATION	DATE	DRAW	APPROVE
A	NEW DWG	2007.07.04	HUANG	KEVIN

NOTES

1: MATERIAL:
SHELL: STEEL
HOUSING: PBT+30%G.F, BLACK, UL94V-0
CONTACT: PHOSPHOR BRONZE AND BRASS

2: FINISH:
SHELL: NICKEL PLATING
CONTACT PLATING: GOLD PLATING

3: SPECIFICATION:
CURRENT RATING: 40A
VOLTAGE RATING: 300V
CONTACT RESISTANCE: 10m Ω
WITHSTANDING VOLTAGE: 1000V
INSULATION RESISTANCE: 5000M Ω
OPERATING TEMPERATURE: -55°C~105°C

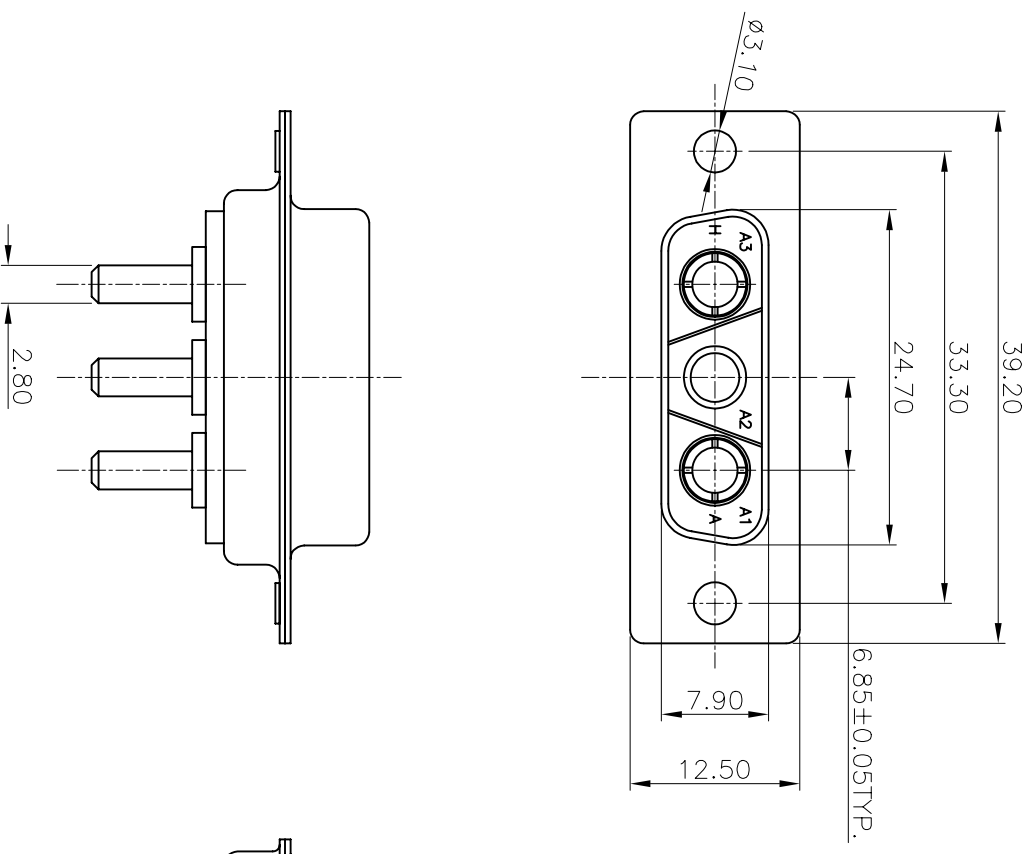

-TOLERANCES-		UNLESS OTHERWISE SPECIFIED	
X.X	± 0.30	X.X°	$\pm 3^\circ$
X.XX	± 0.15	X.XX°	$\pm 1^\circ$
X.XXX	± 0.10	X.XXX°	$\pm 0.5^\circ$

		TITLE: 3V3 两母一公插板成品
--	--	---------------------

APPD: KEVIN	PRODUCT NO: 133-003FPXMK06
CHECK: TENA	DATE: 2007.07.04
DRAW: HUAN	SCALE: FRBE
	UNIT: MM
	TYPE: Y
	PAGE: 1/1