

REV	MODIFICATION	DATE	DRAW	APPROVE
A	NEW DWG	2007.07.10	HUANG	KEVIN

NOTES

1: MATERIAL:  
SHELL: SPCC  
HOUSING: PBT+30%G.F, BLACK, UL94V-0  
CONTACT: BRASS or PHOSPHOR BRONZE

2: FINISH:  
SHELL: NICKEL PLATING  
CONTACT PLATING: GOLD PLATING

3: SPECIFICATION:  
CURRENT RATING: 40A  
VOLTAGE RATING: 300V  
CONTACT RESISTANCE: 10mΩ  
WITHSTANDING VOLTAGE: 1000V  
INSULATION RESISTANCE: 5000MΩ  
OPERATING TEMPERATURE: -55°C~105°C

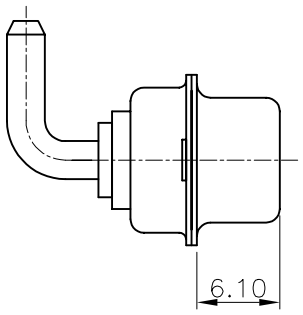
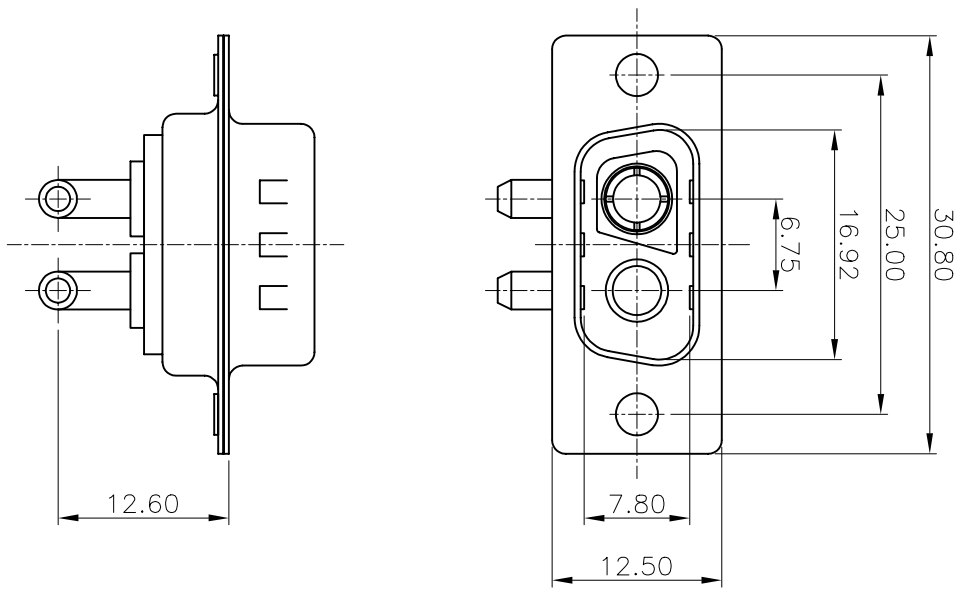

-TOLERANCES-  
UNLESS OTHERWISE SPECIFIED

X.X	±0.30	X.X°	±3°	⊕	⊖	TITLE: 2V2 MALE 折弯成品(一公一母)				
X.XX	±0.15	X.XX°	±1°	APPD:	KEVIN	PRODUCT NO: 134-002MBXMK02				
X.XXX	±0.10	X.XXX°	±0.5°	CHECK:	TENA	DATE	SCALE	UNIT	TYPE	PAGE
				DRAW:	HUANG	2007.07.10	FRBE	MM	Y	1/1

1	2	3	4	5	6	7	8	9	10
A	B	C	D	E	F	G			