

REV	MODIFICATION	DATE	DRAW	APPROVE
A	NEW DWG	2007.07.10	HUANG	KEVIN

NOTES

1: MATERIAL:  
SHELL: SPCC  
HOUSING: PBT+30%G.F, BLACK, UL94V-0  
CONTACT: BRASS or PHOSPHOR BRONZE

2: FINISH:  
SHELL: NICKEL PLATING  
CONTACT PLATING: GOLD PLATING

3: SPECIFICATION:  
CURRENT RATING: 40A  
VOLTAGE RATING: 300V  
CONTACT RESISTANCE: 10mΩ  
WITHSTANDING VOLTAGE: 1000V  
INSULATION RESISTANCE: 5000MΩ  
OPERATING TEMPERATURE: -55°C~105°C

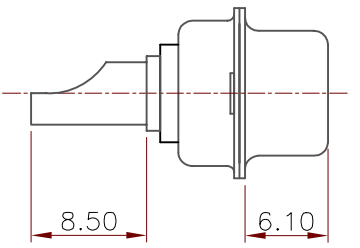
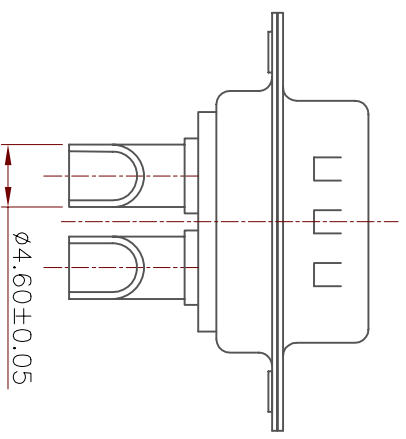
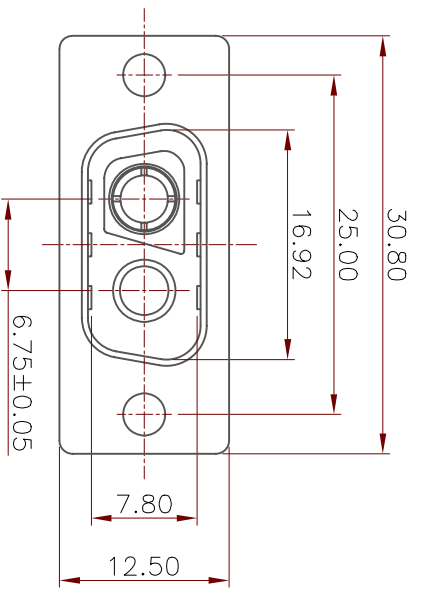

-TOLERANCES-		UNLESS OTHERWISE SPECIFIED	
X.X	±0.30	X.X°	±3°
X.XX	±0.15	X.XX°	±1°
X.XXX	±0.10	X.XXX°	±0.5°



TITLE: 2V2 MALE SOLDER 成品(一公一母)

APPD:	KEVIN	PRODUCT NO:	131-002MBXMK06
CHECK:	TENA	DATE:	2007.07.10
DRAW:	HUANG	SCALE:	FRBE
		UNIT:	MM
		TYPE:	Y
		PAGE:	1/1