

REV	MODIFICATION	DATE	DRAW	APPROVE
A	NEW DWG	2007.07.10	HUANG	KEVIN

NOTES

- 1: MATERIAL:  
SHELL: STEEL  
HOUSING: PBT+30%G.F, BLACK, UL94V-0  
CONTACT: BRASS
- 2: FINISH:  
SHELL: NICKEL PLATING  
CONTACT PLATING: GOLD PLATING
- 3: SPECIFICATION:  
CURRENT RATING: 40A  
VOLTAGE RATING: 300V  
CONTACT RESISTANCE: 10mΩ  
WITHSTANDING VOLTAGE: 1000V  
INSULATION RESISTANCE: 5000MΩ  
OPERATING TEMPERATURE: -55°C~105°C

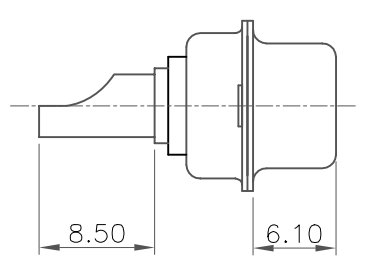
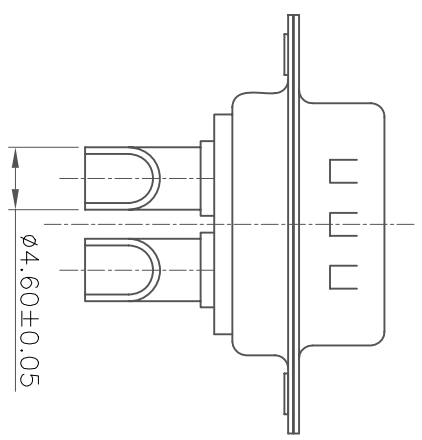
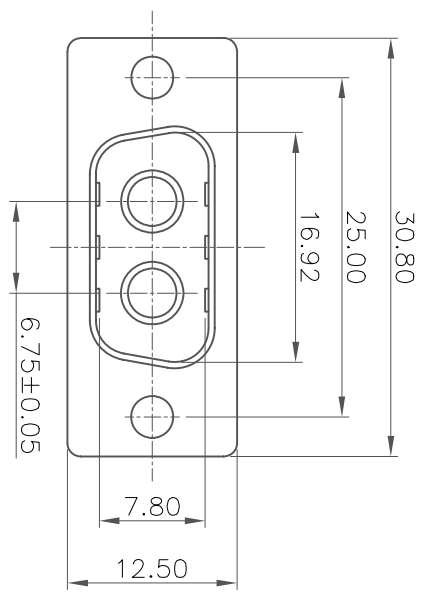

-TOLERANCES-  
UNLESS OTHERWISE SPECIFIED



TITLE: 2W2 MALE SOLDER 成品

X.X	±0.30	X.X°	±3°	APPD: KEVIN	PRODUCT NO: 131-002MBXMK01	
X.XX	±0.15	X.XX°	±1°	CHECK: TENA	DATE	SCALE
X.XXX	±0.10	X.XXX°	±0.5°	DRAW: HUANG	2007.07.10	UNIT
					FRBE	MM
						Y
						TYPE
						PAGE
						1/1