

REV	MODIFICATION	DATE	DRAW	APPROVE
A	NEW DWG	2007.07.04	HUANG	KEVIN

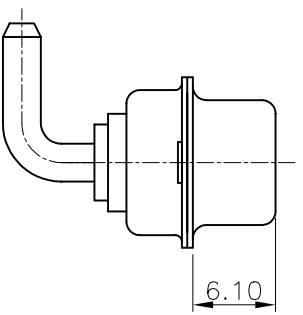
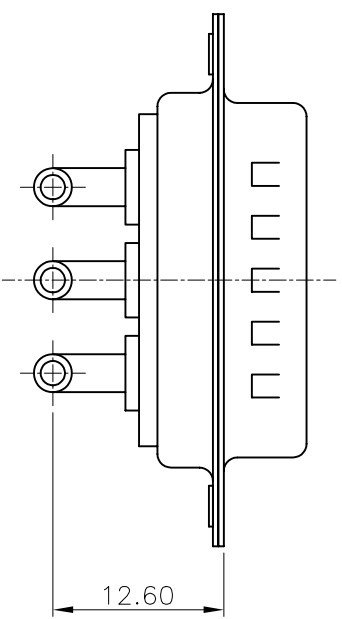
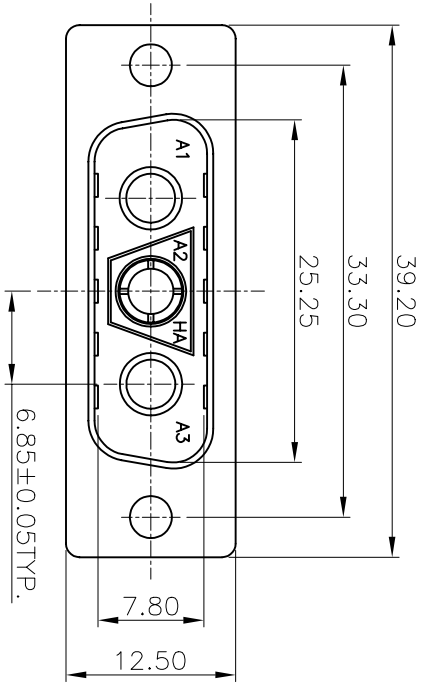

NOTES
 1: MATERIAL:
 SHELL: STEEL
 HOUSING: PBT+30%G.F, BLACK, UL94V-0
 CONTACT: BRASS AND PHOSPHOR BRONZE
 2: FINISH:
 SHELL: NICKEL PLATING
 CONTACT PLATING: GOLD PLATING
 3: SPECIFICATION:
 CURRENT RATING: 40A
 VOLTAGE RATING: 300V
 CONTACT RESISTANCE: 10mΩ
 WITHSTANDING VOLTAGE: 1000V
 INSULATION RESISTANCE: 5000MΩ 5
 OPERATING TEMPERATURE: -55°C~105°C

-TOLERANCES-
 UNLESS OTHERWISE SPECIFIED

X.X	±0.30	X.X°	±3°		TITLE: 3W3 两公一母 SOLDER 成品 PRODUCT NO: 131-003MBXMK06
X.XX	±0.15	X.XX°	±1°		
X.XXX	±0.10	X.XXX°	±0.5°		
APPD: KEVIN		CHECK: TENA		DATE	SCALE
DRAW: HUANG		DATE		FRBE	UNIT
		2007.07.04		MM	TYPE
				Y	PAGE
					1/1