

REV	MODIFICATION	DATE	DRAW	APPROVE
A	NEW DWG	2007.07.04	HUANG	KEVIN

NOTES

1: MATERIAL:
SHELL: STEEL
HOUSING: PBT+30%G.F, BLACK, UL94V-0
CONTACT: BRASS

2: FINISH:
SHELL: NICKEL PLATING
CONTACT PLATING: GOLD PLATING

3: SPECIFICATION:
CURRENT RATING: 7.5A-40A
VOLTAGE RATING: 300V
CONTACT RESISTANCE: 10mΩ
WITHSTANDING VOLTAGE: 1000V
INSULATION RESISTANCE: 5000MΩ
OPERATING TEMPERATURE: -55°C~105°C

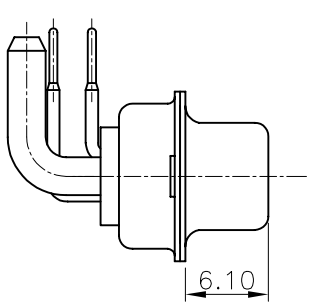
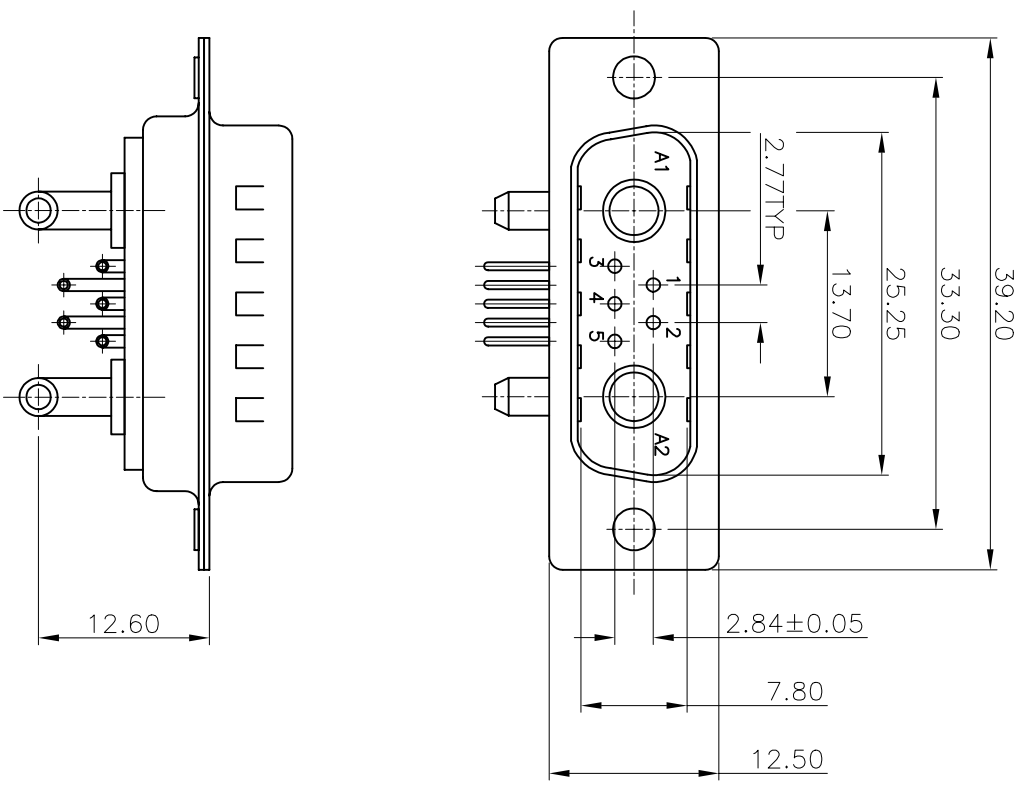

-TOLERANCES-		UNLESS OTHERWISE SPECIFIED	
X.X	±0.30	X.X°	±3°
X.XX	±0.15	X.XX°	±1°
X.XXX	±0.10	X.XXX°	±0.5°

		TITLE:	7W2 MALE 插弯成品
--	--	--------	---------------

APPD:	KEVIN	PRODUCT NO:	134-007MBXMK01
CHECK:	TENA	DATE:	2007.07.04
DRAW:	HUANG	SCALE:	UNIT
		FREE	MM
			Y
			1/1